

# TECHNICAL SPECIFICATIONS

## Magnum Pro 2000

Dimensions:	See figure 1
Weight (empty tank):	13 Kg (28.5 lb)
AC-voltage - 230 V model:	200 - 260 V
AC-voltage - 115 V model:	100 - 130 V
AC-frequency:	50 / 60 Hz
Power consumption:	1700 W
Maximum fluid consumption:	0.2 l/min
Tank capacity:	9.5 l (2.5 gallon)
Warm-up time:	8 - 10 min
Fuse:	10 AT at 200 - 260 V 15 AT at 100 - 130 V
Overheat protection:	Electronic / Mechanical (with manual reset)

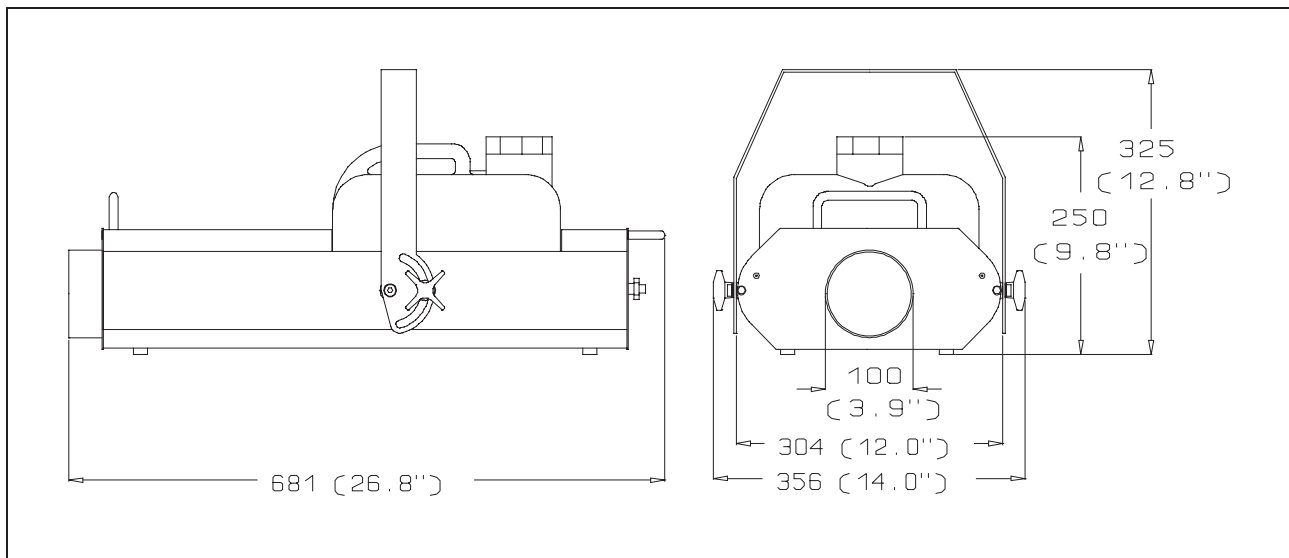

Figure 1: Overall dimensions in mm (inches).

PS-950307